

ZCC

Headquarters:

ZHUZHOU CEMENTED CARBIDE GROUP CORP. LTD.

📍 Diamond Building, Diamond Road, Hetang District, Zhuzhou, Hunan, China.

☎ Tel: +86 – 731 – 22968649/28264008

📠 Fax: +86 – 731 – 28222044

✉ Post Code: 412000

🌐 Website <http://www.chinacarbide.com> ✉ E-mail zccc@chinacarbide.com

2020 VERSION



ZCC

ZHUZHOU CEMENTED CARBIDE GROUP CORP.LTD

RODS & BARS PRODUCTS

ABOUT US

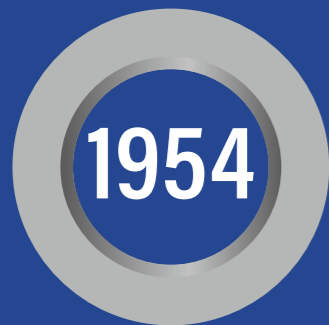

FOUNDATION

One of the 156 major projects that China constructed in 1954 in its "First Five-Year Plan".

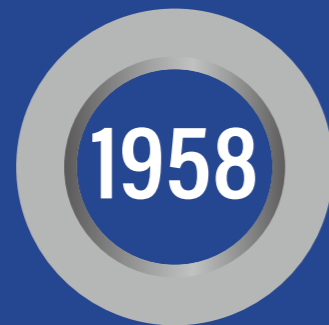

THE FIRST ROD

China's 1st piece of ROD was born in ZCC.



THE FIRST ROD WITH COOLANT HOLES

China's 1st piece of ROD WITH COOLANT HOLES was born in ZCC.



RODS & BARS DIVISION BUILT

Isolated division for rods only in order to avoid cross contamination!



NEW DRILL BLANKS!

New production line and have sold one million pieces !

Zhuzhou Cemented Carbide Group Corporation Ltd(ZCC) was one of the 156 major projects that China constructed in 1954 in its "First Five-Year Plan". It is China's professional base in the production, scientific research, sales and export of cemented carbide. Its main products fall into 3 major categories- "cemented carbide, tungsten and molybdenum products, and tantalum and niobium products. They are widely used in industries of metallurgy, machinery, mining, petroleum-chemistry, electronics, etc.,



OUR PROCESS

ZCC's rod & bar division is a specialized carbide rod & bar manufacturer under ZCC. In 1958, China's first piece of cemented carbide rod was born here. Currently, with 300 professional employees and three specialized workshops, ZCC's rod & bar division is producing about 2000 tons of rods annually and more than one-third are exported to worldwide-famous cutting tool manufacturers.

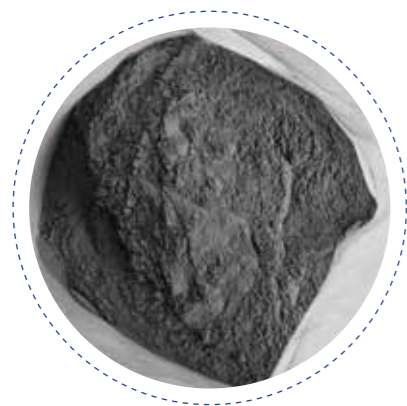

POWDER



FORMING



SINTERING



MACHINING



INSPECTION

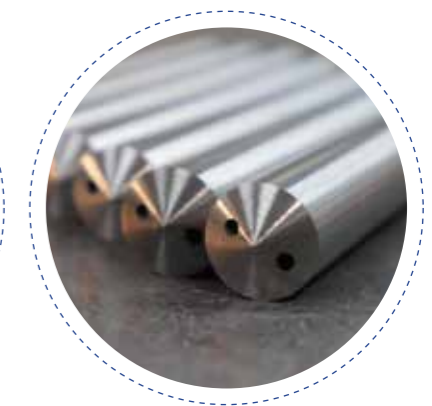

PACKAGING

OUR QUALITY

THE ONLY "STATE KEY LABORATORY" OF CEMENTED CARBIDE



GEOMETRICALLY

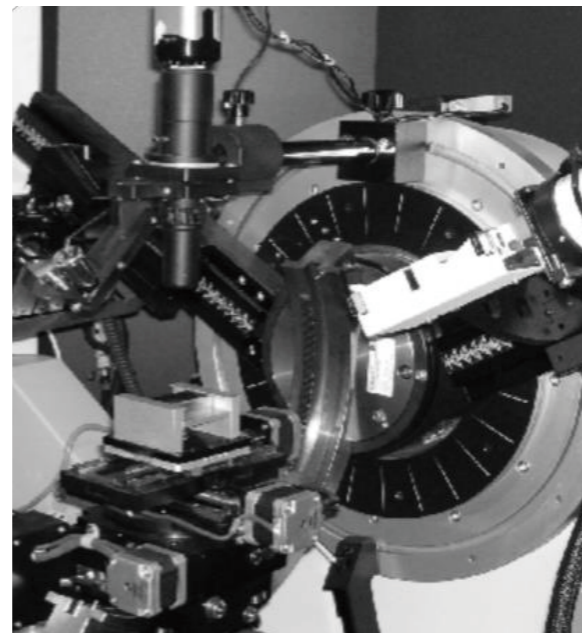

METALLURGICALLY

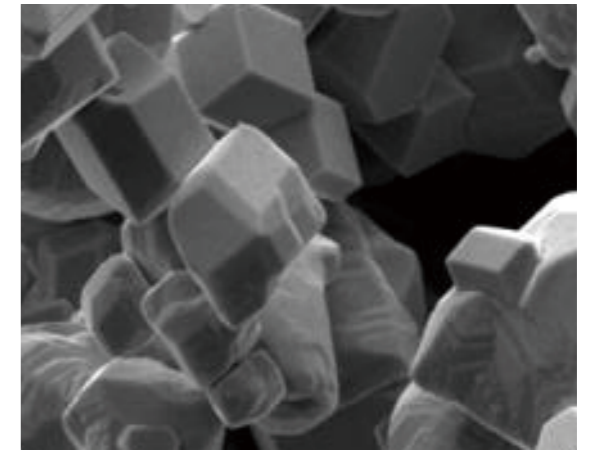



ENGINEERING



AUTOMOTIVE

APPLICATION



3C



AEROSPACE

WE HAVE THE RIGHT PRODUCTION!



RODS

DRILL BLANKS	14

ENDMILL BLANKS	17
Endmill blanks with weldon shank	18
Ball nose rods	19

SOLID	20

RODS WITH COOLANT HOLES	29
2 coolant holes, 30° helix	31
2 coolant holes, 40° helix	33
2 coolant holes, 45° helix	34
3 coolant holes, 30° helix	35
3 coolant holes, 40° helix	36
Central coolant hole	37
2 parallel holes	38

PCB RODS	40
GUN DRILLS	44
PREFORMS	51
STRIPS	52

PRODUCTIONS

GRADE OVERVIEW

For Cutting Tools

GRADE		YL06C	YL10.2	YL10A	YF06	XF20S	XF30S	XT30S	XU30	XU09S	XU10W
Grain size	μm	1.0	0.8	0.8	0.6	0.6	0.6	0.6	0.4	0.4	0.4
WC+Others	%	94	90	92	94	90	88	88	88	91	97
Co	%	6	10	8	6	10	12	12	12	9	3
Density	g/cm ²	14.96	14.42	14.65	14.9	14.37	14.14	14.12	14.1	14.40	15.25
HV30	kg/mm ²	1720	1600	1780	1850	1630	1700	1580	1750	1940	2100
HRA	ISO3738	92.5	91.5	92.8	93.1	91.9	92.3	91.8	92.5	93.4	94.4
TRS (sample C*)	N/mm ²	3800	4000	3800	3600	4200	4800	4500	4000	4200	2400
KIC	MN ^{-3/2}	9.50	10.20	9.80	9.20	10.50	10.00	12.00	9.50	9.00	8.00
Porosity	A	<02	<02	<02	<02	<02	<02	<02	<02	<02	<02
	B	00	00	00	00	00	00	00	00	00	00
	C	00	00	00	00	00	00	00	00	00	00

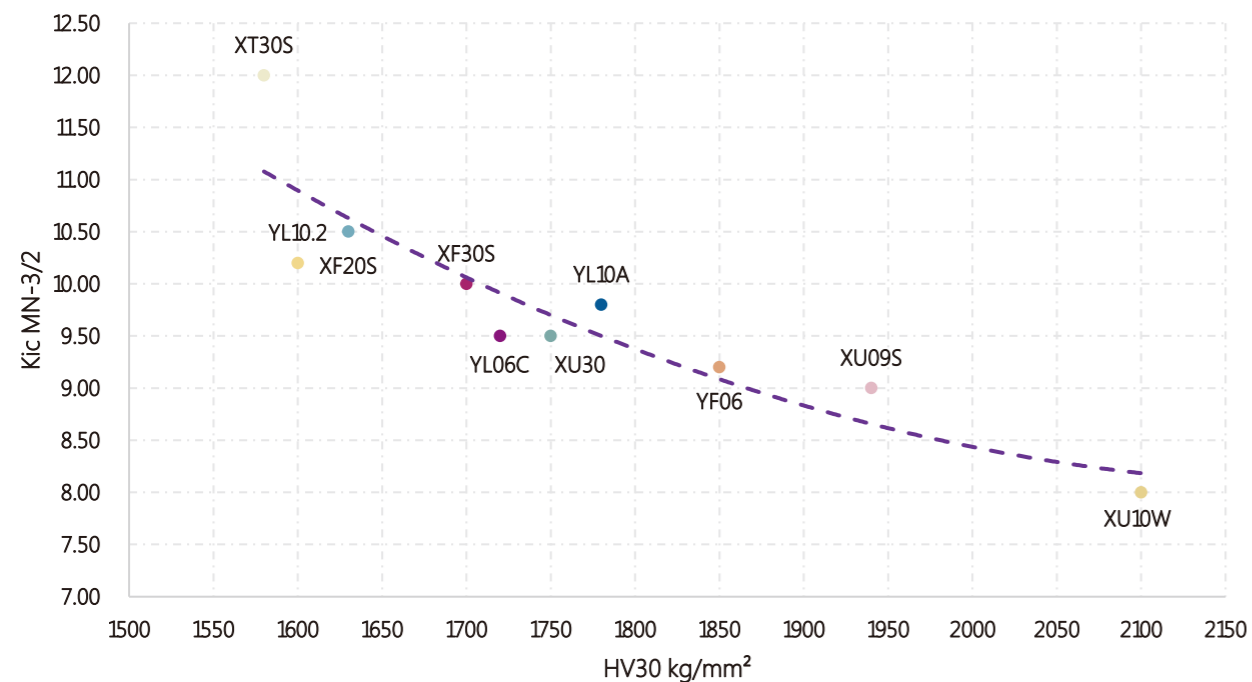

*) Ground cylindrical test specimen 3.25 mm dia. × 38 mm long.
Testing conditions according to ISO3327.

APPLICATION

GRADE	YL06C	YL10.2	YL10A	YF06	XF20S	XF30S	XT30S	XU30	XU09S	XU10W
Drilling	✓	✓	✓	✓	✓					
Milling	✓	✓	✓		✓	✓	✓	✓	✓	✓
Reaming				✓						
General carbon steel		★		●	★	★		●		
Stainless steel			●		●		★			
Cast Iron		★	●		★	★		●		
Ti					●		★			
HRSA						●				
Al-Mg		★	●	★	★	★		●		
Hard steel									★	
Plastic		●			●					
CFRP	★(coated)									
Wood				●	★	●				★
Ceramic	★(coated)									

★ Best choice
● Good choice



PCB RODS

For PCB Tools

GRADE		XF15S	YU06A	XN20A	XN208	XN209
Grain size	μm	0.8	0.4	0.3	0.2	0.2
WC+Others	%	94	94	92	92	91
Co	%	6	6	8	8	9
Density(G/cm ³)	g/cm ²	14.94	14.75	14.58	14.5	14.36
HV30	kg/mm ²	1880	2100	2020	2150	2050
HRA	ISO3738	93.1	94.7	93.6	95	94.2
TRS(N/mm ²) (sample C)	N/mm ²	4000	3800	5000	4700	4800
KIC	MN ^{-3/2}	9.20	8.31	9.80	8.50	8.80
Porosity	A	<02	<02	<02	<02	<02
	B	00	00	00	00	00
	C	00	00	00	00	00

For Router

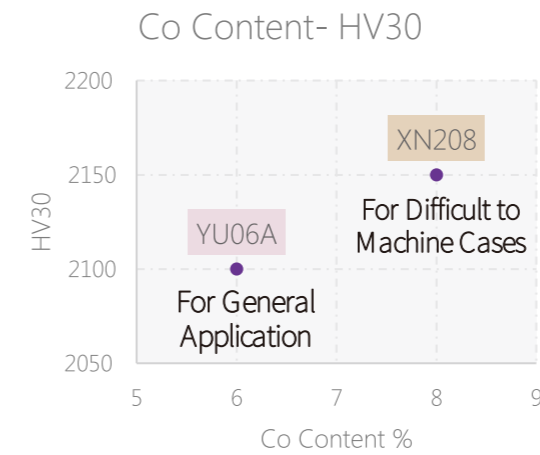

For Drill

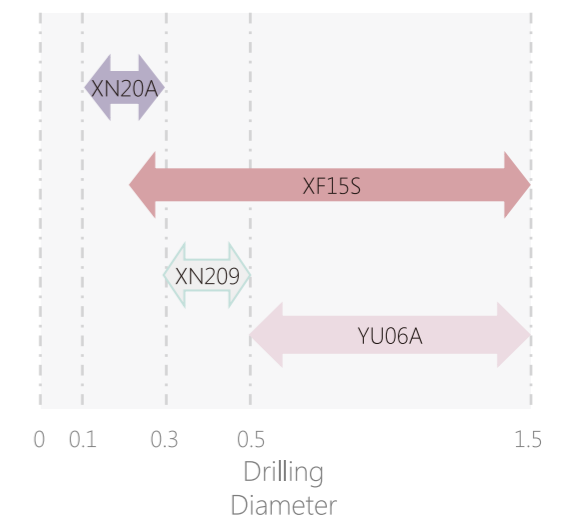
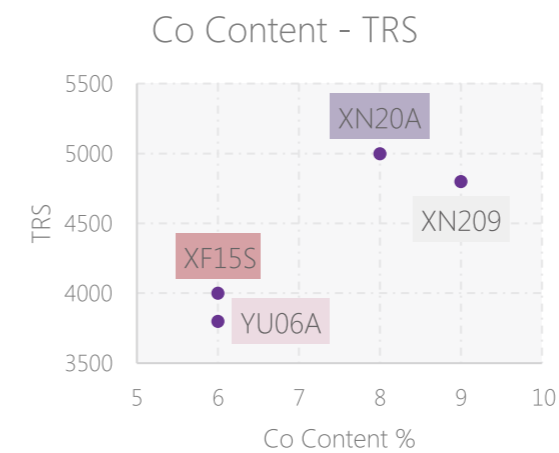

APPLICATIONS

DRILL BLANKS



Ground Drill Blanks with Point

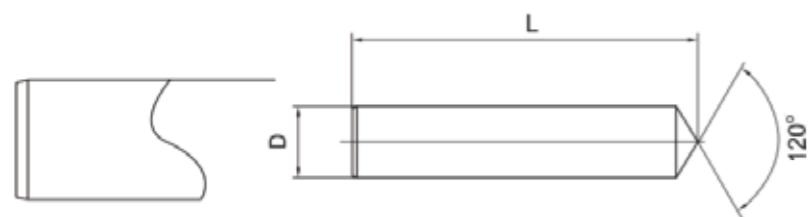

TYPE	D mm	L mm	TYPE	D mm	L mm
ZY05063GD	5	63	ZY18124GD	18	124
ZY06067GD	6	67	ZY19128GD	17	128
ZY07075GD	7	157	ZY20132GD	26	132
ZY08080GD	8	163	ZY21137GD	27	137
ZY09085GD	9	163	ZY22142GD	28	112
ZY10090GD	10	75	ZY23147GD	29	116
ZY11096GD	11	80	ZY24152GD	30	120
ZY12103GD	12	85	ZY25152GD	30	120
ZY13103GD	13	90	ZY26157GD	21	169
ZY14108GD	14	96	ZY27163GD	22	142
ZY15112GD	15	103	ZY28163GD	23	147
ZY16116GD	16	103	ZY29169GD	24	152
ZY17120GD	19	108	ZY30169GD	25	152

GROUND D (mm)		L (mm)	
Range	Tol.	Range	Tol.
0.5 ≤ D ≤ 30	h5/h6		0/+2.00

Ground Drill Blanks with Point, Slot and Helical Coolant Holes

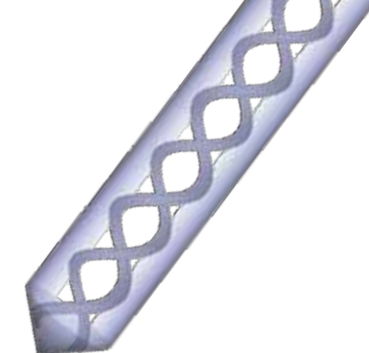
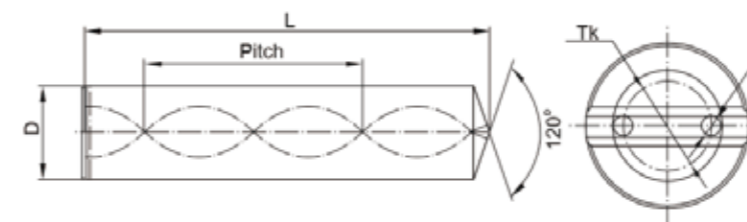

TYPE	D mm	L mm	d mm	TK mm	PITCH(mm)			
					P1	P2	P3	Tol.
ZY305030530400170GD	3	53	0.40	1.70	15.89	16.32	16.77	±0.23
ZY305040590600220GD	4	59	0.60	2.20	21.19	21.77	22.36	±0.31
ZY305050630700260GD	5	63	0.70	2.60	26.49	27.21	27.95	±0.38
ZY305060670700260GD	6	67	0.70	2.60	31.79	32.65	33.54	±0.46
ZY305070751000370GD	7	75	1.00	3.70	37.09	38.09	39.13	±0.54
ZY305080801000400GD	8	80.5	1.00	4.00	42.38	43.53	44.73	±0.62
ZY305090851400480GD	9	85	1.40	4.80	47.68	48.97	50.32	±0.69
ZY305100901400480GD	10	90.5	1.40	4.80	52.98	54.41	55.91	±0.77
ZY305110981100530GD	11	98	1.10	5.30	58.28	59.86	61.50	±0.85
ZY305121041400625GD	12	104	1.40	6.25	63.58	65.30	67.09	±0.92
ZY305131061750650GD	13	106.5	1.75	6.50	68.87	70.74	72.68	±1.00
ZY305141091750710GD	14	109	1.75	7.10	74.17	76.18	78.27	±1.08
ZY305151131750770GD	15	113	1.75	7.70	79.47	81.62	83.86	±1.15
ZY305161171750830GD	16	117.5	1.75	8.30	84.77	87.06	89.45	±1.23
ZY305171211750890GD	17	121	1.75	8.90	90.07	92.50	95.04	±1.31
ZY305181252000955GD	18	125.5	2.00	9.55	95.36	97.95	100.63	±1.38
ZY305191302001010GD	19	130	2.00	10.10	100.66	103.39	106.22	±1.46
ZY305201342001040GD	20	134	2.00	10.40	105.96	108.83	111.81	±1.54

GROUND D (mm)		L (mm)	
Range	Tol.	Range	Tol.
3 ≤ D ≤ 20	h5/h6	L > 100	0/+2.00
		L ≤ 100	0/+1.50

d (mm)		TK (mm)	
Range	Tol.	Range	Tol.
d ≤ 0.4	±0.10	d ≤ 4.3	0/-0.3
0.4 < d ≤ 1.4	±0.15	4.3 < d ≤ 8.3	0/-0.4
0.4 < d ≤ 1.75	±0.20	8.3 < d ≤ 10.3	0/-0.6
1.75 < d ≤ 2.0	±0.25	10.3 < d ≤ 19.3	0/-0.8
		d = 20.3	0/-1.0

ENDMILL BLANKS



Endmill Blanks With Weldon Shank

DIN6535HB

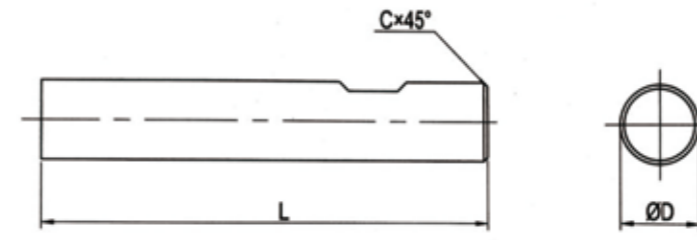

D h6 mm	L mm		Chamfer mm	
6	57	+1/0	0.5	±0.1
8	63	+1/0	0.6	±0.1
10	72	+1/0	0.6	±0.1
12	83	+1/0	0.8	±0.1
14	83	+1/0	0.8	±0.1
16	92	+1/0	0.8	±0.1
18	92	+1/0	0.8	±0.1
20	104	+1/0	1.0	±0.1

MORE TYPES ARE AVAILABLE ON REQUEST!

Ball Nose Rods

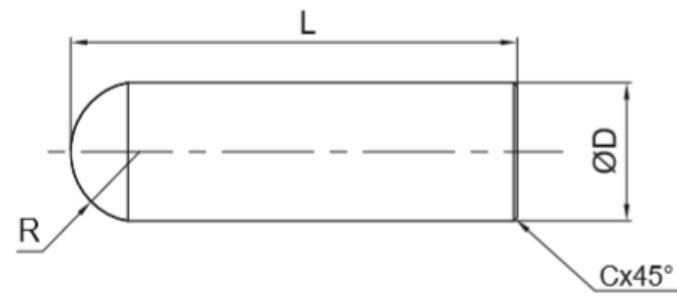

SOLID



D inch	D h6 inch	L inch		Probe-radius	
				R	Tol.
1/4	1/4	2.0	0/+0.063	0.265	±0.005
1/4	1/4	2.5	0/+0.063	0.265	±0.005
5/16	5/16	2.5	0/+0.063	0.325	±0.005
3/8	3/8	2.5	0/+0.063	0.390	+0.010/-0.005
7/16	7/16	2.75	0/+0.063	0.453	+0.010/-0.005
1/2	1/2	3.0	0/+0.063	0.515	+0.010/-0.005
5/8	5/8	3.5	0/+0.063	0.64	+0.012/-0.006
3/4	3/4	4.0	0/+0.08	0.77	+0.015/-0.008
1	1	4.0	0/+0.08	1.020	+0.015/-0.008

D mm	D h6 mm	L mm	
6	6	58	0/+0.5
8	8	64	0/+0.5
10	10	73	0/+0.5
12	12	84	0/+0.5
14	14	84	0/+0.5
16	16	93	0/+0.5
18	18	93	0/+0.5
20	20	105	0/+0.5

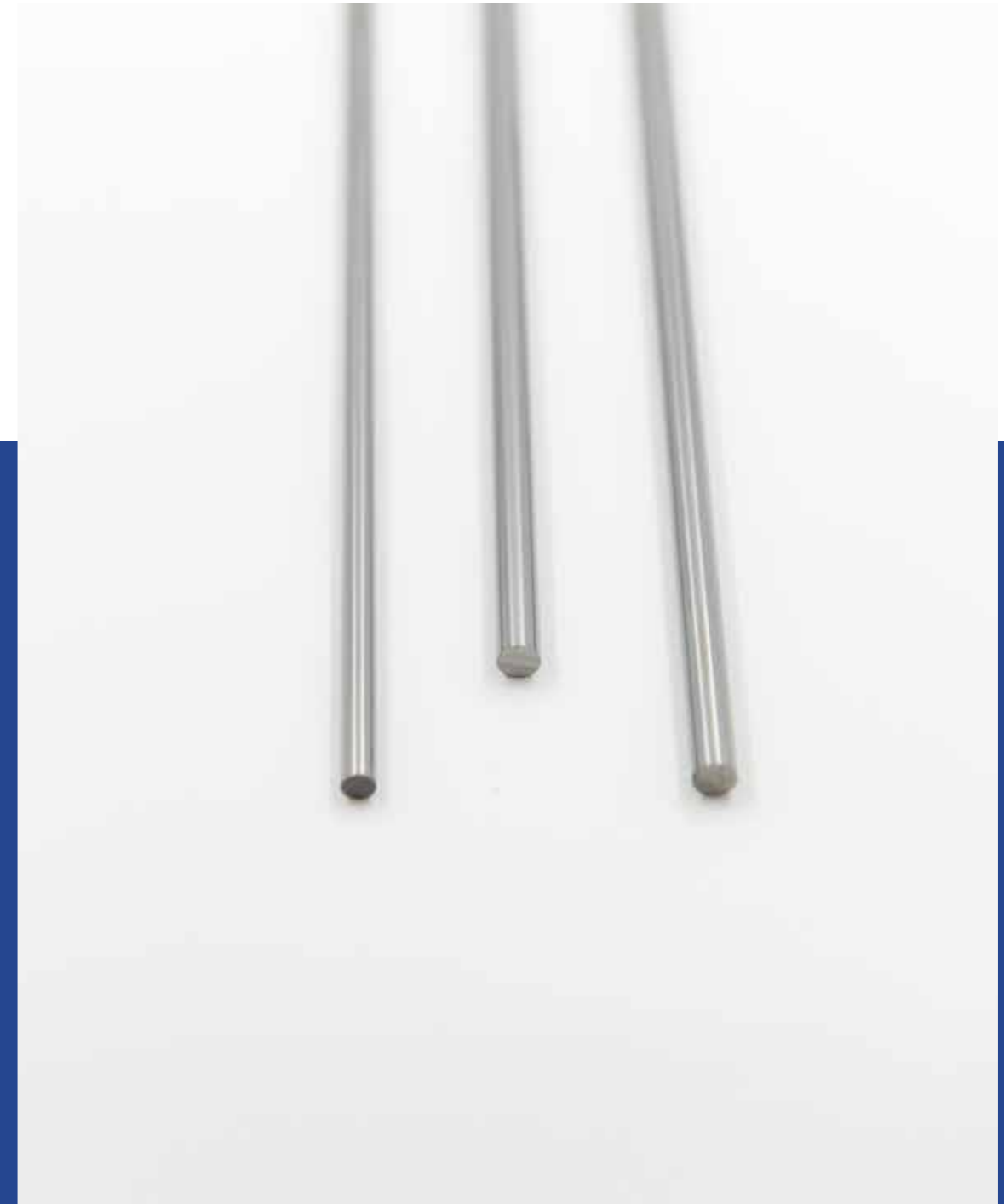

MORE TYPES ARE AVAILABLE ON REQUEST!

Solid

Length:330/310mm (0/+10.0)



D mm	D h5/h6 mm	D mm	D h5/h6 mm
0.5	+0.10/0.20	13.5	+0.20/0.60
1.0	+0.10/0.20	14.0	+0.20/0.60
1.2	+0.10/0.20	14.5	+0.20/0.60
1.6	+0.10/0.20	15.0	+0.20/0.60
1.8	+0.10/0.20	15.5	+0.20/0.60
2.0	+0.10/0.20	16.0	+0.20/0.60
2.3	+0.10/0.30	16.5	+0.20/0.60
2.5	+0.10/0.30	17.0	+0.20/0.60
3.0	+0.10/0.30	17.5	+0.20/0.60
3.5	+0.10/0.30	18.0	+0.20/0.60
4.0	+0.20/0.50	18.5	+0.20/0.60
4.5	+0.20/0.50	19.0	+0.20/0.60
5.0	+0.20/0.50	19.5	+0.20/0.60
5.5	+0.20/0.50	20.0	+0.20/0.60
6.0	+0.20/0.50	21.0	+0.20/0.65
6.5	+0.20/0.50	22.0	+0.20/0.65
7.0	+0.20/0.50	23.0	+0.20/0.65
7.5	+0.20/0.50	24.0	+0.20/0.65
8.0	+0.20/0.50	25.0	+0.20/0.65
8.5	+0.20/0.50	26.0	+0.20/0.65
9.0	+0.20/0.50	27.0	+0.20/0.65
9.5	+0.20/0.50	28.0	+0.20/0.65
10.0	+0.20/0.50	29.0	+0.20/0.65
10.5	+0.20/0.50	30.0	+0.20/0.65
11.0	+0.20/0.50	31.0	+0.20/0.65
11.5	+0.20/0.50	32.0	+0.20/0.65
12.0	+0.20/0.60	33.0	+0.20/0.65
12.5	+0.20/0.60	34.0	+0.20/0.65
13.0	+0.20/0.60	35.0	+0.20/0.65

MORE TYPES ARE AVAILABLE ON REQUEST!

Solid

With 45° Chamfer, fix length

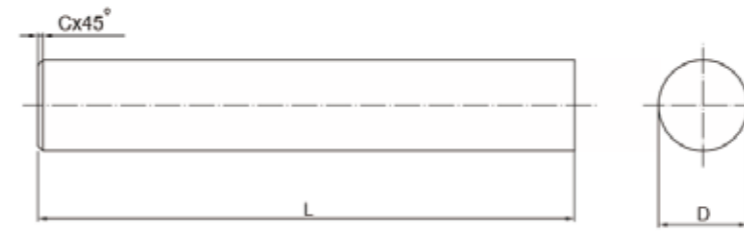

D h5/h6 mm	L mm	Chamfer mm	D h5/h6 mm	L mm	Chamfer mm
2.0	32	0/+0.5	10.0	70	0/+0.5
3.0	32	0/+0.5	10.0	72	0/+0.5
3.0	39	0/+0.5	11.0	70	0/+0.5
4.0	38	0/+0.5	11.0	72	0/+0.5
4.0	40	0/+0.5	12.0	70	0/+0.5
4.0	51	0/+0.5	12.0	73	0/+0.5
5.0	38	0/+0.5	12.0	84	0/+0.5
5.0	51	0/+0.5	12.0	100	0/+0.5
5.0	57	0/+0.5	13.0	75	0/+0.5
6.0	39	0/+0.5	14.0	75	0/+0.5
6.0	45	0/+0.5	14.0	84	0/+0.5
6.0	51	0/+0.5	15.0	75	0/+0.5
6.0	55	0/+0.5	16.0	75	0/+0.5
6.0	57	0/+0.5	16.0	82	0/+0.5
7.0	60	0/+0.5	16.0	92	0/+0.5
8.0	58	0/+0.5	18.0	84	0/+0.5
8.0	60	0/+0.5	18.0	93	0/+0.5
8.0	64	0/+0.5	18.0	100	0/+0.5
9.0	60	0/+0.5	20.0	92	0/+0.5
9.0	63	0/+0.5	20.0	100	0/+0.5
10.0	66	0/+0.5	20.0	104	0/+0.5

MORE TYPES ARE AVAILABLE ON REQUEST!

Solid

With 45° Chamfer,
length : 100mm(0/+0.5)

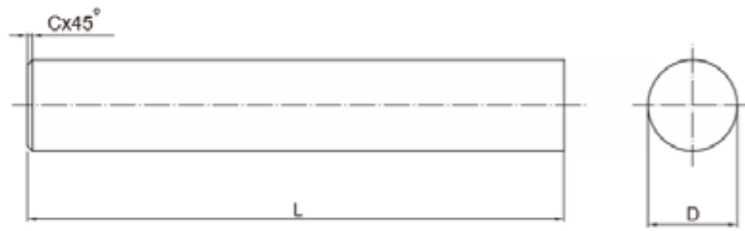

D h5/h6 mm	Chamfer mm	D h5/h6 mm	Chamfer mm
1.0	0.3	13.0	0.7
1.5	0.3	14.0	0.7
2.0	0.3	15.0	0.7
2.5	0.3	16.0	0.7
3.0	0.3	18.0	1.0
3.5	0.3	19.0	1.0
4.0	0.3	20.0	1.0
4.5	0.3	21.0	1.0
5.0	0.3	22.0	1.0
5.5	0.3	23.0	1.0
6.0	0.5	24.0	1.0
6.5	0.5	25.0	1.5
7.0	0.5	26.0	1.5
7.5	0.5	28.0	1.5
8.0	0.5	30.0	1.5
8.5	0.5	32.0	1.5
9.0	0.5	33.0	1.5
9.5	0.5	34.0	1.5
10.0	0.5	35.0	1.5
10.5	0.5	36.0	1.5
11.0	0.5	38.0	1.5
11.5	0.5	40.0	1.5
12.0	0.7		

MORE TYPES ARE AVAILABLE ON REQUEST!

Solid

Inch sizes, polished, with 45° Chamfer,
fix length

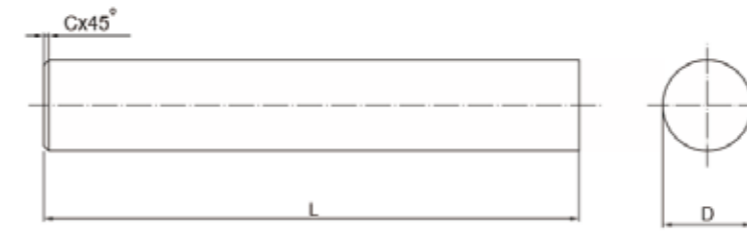

D h6 mm	L mm	Chamfer mm
1/16	1-1/2 0/+0.02	0.2
3/32	1.04 0/+0.02	0.2
3/32	1-3/4 0/+0.02	0.2
3/32	2 0/+0.02	0.2
1/8	1 0/+0.02	0.3
1/8	1-1/2 0/+0.02	0.3
1/8	2 0/+0.02	0.3
1/8	2-1/4 0/+0.02	0.3
1/8	2-1/2 0/+0.02	0.3
1/8	3 0/+0.02	0.3
1/8	4 0/+0.02	0.3
1/8	4-1/2 0/+0.02	0.3
1/8	12 0/+0.4	0.3
5/32	2 0/+0.02	0.3
5/32	2-1/2 0/+0.02	0.3
5/32	3 0/+0.02	0.3
5/32	12 0/+0.4	0.3
0.1610	2-1/2 0/+0.02	0.3
11/64	2-3/4 0/+0.02	0.3
11/64	6-1/2 0/+0.02	0.3
11/64	7 0/+0.02	0.3
3/16	1-1/2 0/+0.02	0.4
3/16	2 0/+0.02	0.4
3/16	2-3/16 0/+0.02	0.4
3/16	2-1/4 0/+0.02	0.4
3/16	2-1/2 0/+0.02	0.4
3/16	3 0/+0.02	0.4
3/16	4 0/+0.02	0.4
3/16	6 0/+0.02	0.4

MORE TYPES ARE AVAILABLE ON REQUEST!

Solid

Inch sizes, polished, with 45° Chamfer, fix length

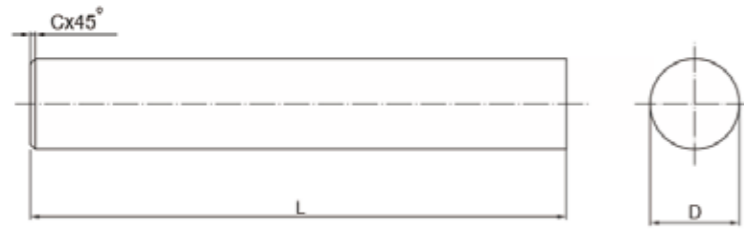

D h6 mm	L mm	Chamfer mm	
.1935	2-3/4	0/+0.02	0.4
13/64	3	0/+0.02	0.4
7/32	3	0/+0.02	0.4
.2188	2.5	0/+0.02	0.4
1/4	1-1/2	0/+0.02	0.4
1/4	2	0/+0.02	0.4
1/4	2-1/2	0/+0.02	0.4
1/4	3	0/+0.02	0.4
1/4	3-1/2	0/+0.02	0.4
1/4	4	0/+0.02	0.4
1/4	4-1/2	0/+0.02	0.4
1/4	5	0/+0.02	0.4
1/4	6	0/+0.02	0.4
1/4	6-1/2	0/+0.02	0.4
1/4	7	0/+0.02	0.4
1/4	8	0/+0.02	0.4
1/4	12	0/+0.4	NO
9/32	1-1/2	0/+0.02	0.6
9/32	2-13/16	0/+0.02	0.6
5/16	1-1/4	0/+0.02	0.6
5/16	2-1/2	0/+0.02	0.6
5/16	3	0/+0.02	0.6
5/16	3-1/2	0/+0.02	0.6
5/16	3-3/4	0/+0.02	0.6
5/16	4	0/+0.02	0.6
5/16	6	0/+0.02	0.6
5/16	12	0/+0.4	NO
11/32	4	0/+0.02	0.6

MORE TYPES ARE AVAILABLE ON REQUEST!

Solid

Inch sizes, polished, with 45° Chamfer, fix length

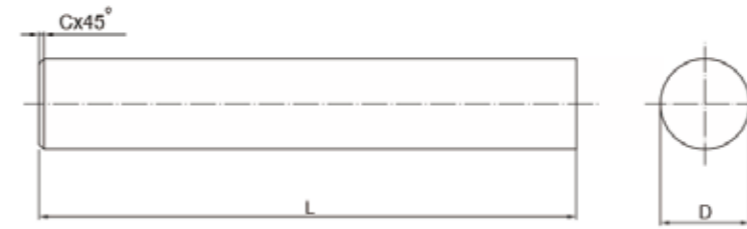

D h6 mm	L mm	Chamfer mm	
23/64	8	0/+0.02	0.6
3/8	2	0/+0.02	0.6
3/8	2-1/2	0/+0.02	0.6
3/8	3	0/+0.02	0.6
3/8	3-1/4	0/+0.02	0.6
3/8	4	0/+0.02	0.6
3/8	4-1/2	0/+0.02	0.6
3/8	5	0/+0.02	0.6
3/8	6	0/+0.02	0.6
3/8	8	0/+0.02	0.6
3/8	6-1/2	0/+0.02	0.6
3/8	12	0/+0.4	0.6
27/64	4	0/+0.02	0.6
27/64	4-1/2	0/+0.02	0.6
7/16	2-1/2	0/+0.02	0.6
7/16	3	0/+0.02	0.6
7/16	3-1/2	0/+0.02	0.6
7/16	4	0/+0.02	0.6
7/16	4-1/2	0/+0.02	0.6
7/16	6	0/+0.02	0.6
7/16	12	0/+0.4	0.6
1/2	2-1/2	0/+0.02	0.6
1/2	3	0/+0.02	0.6
1/2	3-1/4	0/+0.02	0.6
1/2	3-1/2	0/+0.02	0.6
1/2	4	0/+0.02	0.6
1/2	4-1/2	0/+0.02	0.6
1/2	5	0/+0.02	0.6

MORE TYPES ARE AVAILABLE ON REQUEST!

Solid

Inch sizes, polished, with 45° Chamfer, fix length

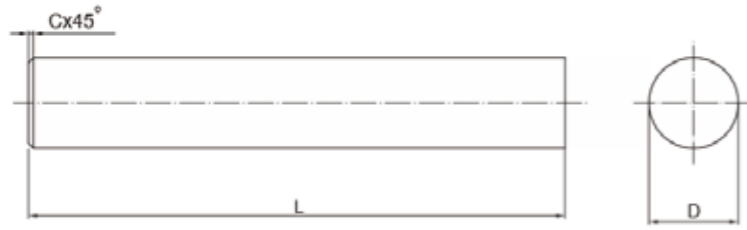

D h6 mm	L mm	Chamfer mm
1/2	6	0/+0.02
1/2	7	0/+0.02
1/2	8	0/+0.02
1/2	8-1/2	0/+0.02
1/2	12	0/+0.4
9/16	3	0/+0.02
9/16	3-1/2	0/+0.02
9/16	4	0/+0.02
9/16	5	0/+0.02
9/16	6	0/+0.02
5/8	3	0/+0.02
5/8	3-1/8	0/+0.02
5/8	3-1/4	0/+0.02
5/8	3-1/2	0/+0.02
5/8	4	0/+0.02
5/8	4-1/2	0/+0.02
5/8	5	0/+0.02
5/8	6	0/+0.02
5/8	7	0/+0.02
5/8	8	0/+0.02
5/8	10	0/+0.02
5/8	12	0/+0.4
3/4	3	0/+0.02
3/4	4	0/+0.02
3/4	5	0/+0.02
3/4	6	0/+0.02
3/4	7	0/+0.02
3/4	8	0/+0.02

MORE TYPES ARE AVAILABLE ON REQUEST!

Solid

Inch sizes, polished, with 45° Chamfer, fix length

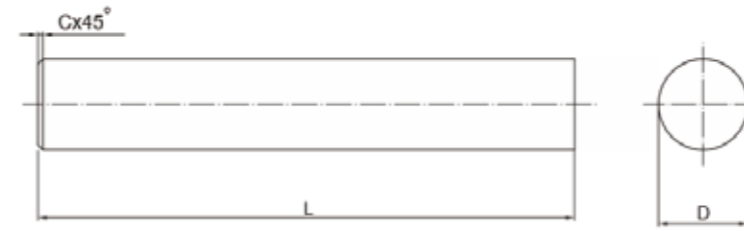

D h6 mm	L mm	Chamfer mm
3/4	10	0/+0.02
3/4	12	0/+0.4
7/8	4	0/+0.02
7/8	5	0/+0.02
7/8	6	0/+0.02
1	3	0/+0.02
1	4	0/+0.02
1	5	0/+0.02
1	6	0/+0.02
1	7	0/+0.02
1	8	0/+0.02
1	9	0/+0.02
1	10	0/+0.02
1	12	0/+0.4
1	12-1/2	0/+0.4
1	13	0/+0.4
1-1/8	4-1/2	0/+0.02
1-1/4	4	0/+0.02
1-1/4	5	0/+0.02
1-1/4	5-1/2	0/+0.02
1-1/4	6	0/+0.02
1-1/4	6-1/2	0/+0.02
1-1/4	7	0/+0.02
1-1/4	7-1/2	0/+0.02
1-1/4	8	0/+0.02
1-1/4	9	0/+0.02
1-1/4	12-1/2	0/+0.4
1-1/2	7-1/2	0/+0.02

MORE TYPES ARE AVAILABLE ON REQUEST!

RODS WITH COOLANT HOLES



2 coolant holes, 30° helix

Length:330/310mm and fix lengths

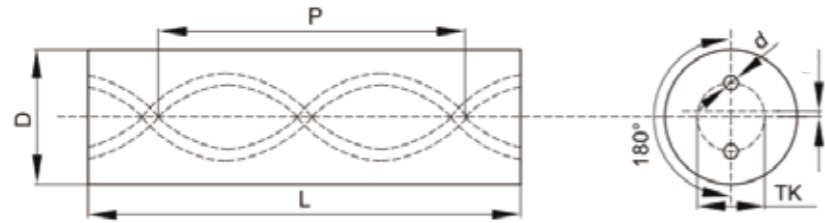

D mm	D h5/h6 mm	d mm	TK mm	CO* mm	Pitch				
					P1	P2	P3	Tol.	
3.3	+0.7/+0.3	3.0	0.4 ±0.10	1.7 0/-0.3	≤0.04	15.89	16.32	16.77	±0.23
4.3	+0.7/+0.3	4.0	0.6 ±0.15	2.2 0/-0.3	≤0.05	21.19	21.77	22.36	±0.31
5.3	+0.8/+0.3	5.0	0.7 ±0.15	2.6 0/-0.4	≤0.10	26.49	27.21	27.95	±0.38
6.3	+1.0/+0.4	6.0	0.7 ±0.15	2.6 0/-0.4	≤0.10	31.79	32.65	33.54	±0.46
6.8	+1.0/+0.4	6.5	1.0 ±0.15	3.5 0/-0.4	≤0.10	34.44	35.37	36.34	±0.50
7.3	+1.0/+0.4	7.0	1.0 ±0.15	3.7 0/-0.4	≤0.10	37.09	38.09	39.13	±0.54
7.8	+1.0/+0.4	7.5	1.0 ±0.15	4.0 0/-0.4	≤0.10	39.73	40.81	41.93	±0.58
8.3	+1.0/+0.4	8.0	1.0 ±0.15	4.0 0/-0.4	≤0.10	42.38	43.53	44.73	±0.62
9.3	+1.0/+0.4	9.0	1.4 ±0.15	4.8 0/-0.6	≤0.15	47.68	48.97	50.32	±0.69
9.8	+1.0/+0.4	9.5	1.4 ±0.15	4.8 0/-0.6	≤0.15	50.33	51.69	53.11	±0.73
10.3	+1.1/+0.4	10.0	1.4 ±0.15	4.8 0/-0.6	≤0.15	52.98	54.41	55.91	±0.77
11.3	+1.1/+0.4	10.0	1.4 ±0.15	5.3 0/-0.8	≤0.18	58.28	59.86	61.5	±0.85
12.3	+1.1/+0.4	12.0	1.4 ±0.15	6.25 0/-0.8	≤0.18	63.58	65.3	67.09	±0.92
13.3	+1.2/+0.4	13.0	1.75 ±0.20	6.5 0/-0.8	≤0.18	68.87	70.74	72.68	±1.00
14.3	+1.4/+0.4	14.0	1.75 ±0.20	7.1 0/-0.8	≤0.18	74.17	76.18	78.27	±1.08
15.3	+1.4/+0.4	15.0	1.75 ±0.20	7.7 0/-0.8	≤0.20	79.47	81.62	83.86	±1.15
16.3	+1.4/+0.4	16.0	1.75 ±0.20	8.3 0/-0.8	≤0.20	84.77	87.06	89.45	±1.23
17.3	+1.4/+0.4	17.0	1.75 ±0.20	8.9 0/-0.8	≤0.20	90.07	92.5	95.04	±1.31
18.3	+1.4/+0.4	18.0	2.0 ±0.20	9.55 0/-0.8	≤0.20	95.36	97.95	100.63	±1.38
19.3	+1.4/+0.4	19.0	2.0 ±0.25	10.1 0/-0.8	≤0.20	100.66	103.39	106.22	±1.46
20.3	+1.4/+0.4	20.0	2.0 ±0.25	10.4 0/-1.0	≤0.20	105.96	108.83	111.81	±1.54
21.3	+1.4/+0.4	21.0	2.0 ±0.25	11.15 0/-1.0	≤0.20	111.26	114.27	117.4	±1.60
22.3	+1.4/+0.4	22.0	2.0 ±0.25	11.6 0/-1.0	≤0.20	116.56	119.71	123.00	±1.69
23.3	+1.4/+0.4	22.0	2.0 ±0.25	12.2 0/-1.0	≤0.20	121.85	125.15	128.59	±1.77
24.3	+1.4/+0.4	24.0	2.0 ±0.25	12.8 0/-1.0	≤0.20	127.15	130.59	134.18	±1.85
25.3	+1.4/+0.4	25.0	2.0 ±0.25	13.3 0/-1.0	≤0.20	132.45	136.03	139.77	±1.92
26.3	+1.4/+0.4	26.0	2.0 ±0.25	13.8 0/-1.0	≤0.20	137.75	141.48	145.36	±2.00
27.3	+1.4/+0.4	24.0	2.5 ±0.30	14.3 0/-1.2	≤0.20	143.05	146.92	150.95	±2.08
28.3	+1.4/+0.4	28.0	2.5 ±0.30	14.8 0/-1.2	≤0.20	148.34	152.36	156.54	±2.15
30.3	+1.4/+0.4	30.0	2.5 ±0.30	16.0 0/-1.2	≤0.20	158.94	163.24	167.72	±2.31

*CO=centre offset
MORE TYPES ARE AVAILABLE ON REQUEST!

2 coolant holes, 30° helix

Length:330/310mm and fix lengths

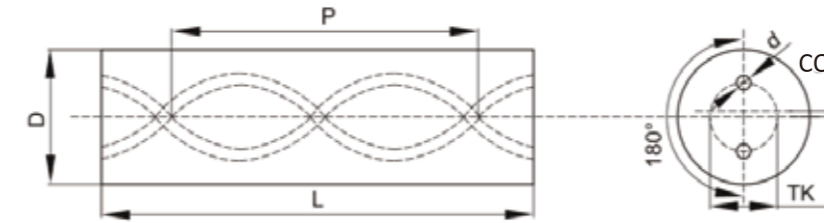

D mm	D h5/h6 mm	d mm	TK mm	CO* mm	Pitch				
					P1	P2	P3	Tol.	
6.3	+1.0/+0.4	6.0	0.3 ±0.10	1.4 0.15/-0.15	≤0.10	31.79	32.65	33.54	±0.46
6.3	+1.0/+0.4	6.0	0.4 ±0.10	1.4 0.15/-0.15	≤0.10	31.79	32.65	33.54	±0.46
6.3	+1.0/+0.4	6.0	0.5 ±0.15	1.5 0.15/-0.15	≤0.10	31.79	32.65	33.54	±0.46
6.3	+1.0/+0.4	6.0	0.5 ±0.15	1.7 0/-0.3	≤0.10	31.79	32.65	33.54	±0.46
6.3	+1.0/+0.4	6.0	0.7 ±0.15	1.9 0/-0.4	≤0.10	31.79	32.65	33.54	±0.46
6.3	+1.0/+0.4	6.0	1.0 ±0.15	2.6 0/-0.4	≤0.10	31.79	32.65	33.54	±0.46
8.3	+1.0/+0.4	8.0	0.5 ±0.15	1.7 0/-0.3	≤0.10	42.38	43.53	44.73	±0.62
8.3	+1.0/+0.4	8.0	0.6 ±0.15	2.8 0/-0.4	≤0.10	42.38	43.53	44.73	±0.62
8.3	+1.0/+0.4	8.0	1.0 ±0.15	3.5 0/-0.4	≤0.10	42.38	43.53	44.73	±0.62
9.3	+1.0/+0.4	9.0	1.0 ±0.15	4.0 0/-0.4	≤0.15	47.68	48.97	50.32	±0.69
10.3	+1.1/+0.4	10.0	0.7 ±0.15	2.6 0/-0.4	≤0.15	52.98	54.41	55.91	±0.77
10.3	+1.1/+0.4	10.0	1.0 ±0.15	3.0 0/-0.4	≤0.15	52.98	54.41	55.91	±0.77
10.3	+1.1/+0.4	10.0	1.0 ±0.15	3.8 0/-0.4	≤0.15	52.98	54.41	55.91	±0.77
10.3	+1.1/+0.4	10.0	1.4 ±0.15	5.0 0/-0.4	≤0.15	52.98	54.41	55.91	±0.77
10.3	+1.1/+0.4	10.0	1.4 ±0.15	4.5 0/-0.6	≤0.15	52.98	54.41	55.91	±0.77
11.3	+1.1/+0.4	11.0	0.9 ±0.15	3.0 0/-0.4	≤0.18	58.28	59.86	61.5	±0.85
12.3	+1.1/+0.4	12.0	1.75 ±0.20	6.0 0/-0.8	≤0.18	63.58	65.3	67.09	±0.92
12.3	+1.1/+0.4	12.0	0.9 ±0.15	4.2 0/-0.6	≤0.18	63.58	65.3	67.09	±0.92
12.3	+1.1/+0.4	12.0	1.4 ±0.15	3.8 +0.2/-0.2	≤0.18	63.58	65.3	67.09	±0.92
12.3	+1.1/+0.4	12.0	1.75 ±0.20	4.5 +0.3/-0.3	≤0.18	63.58	65.3	67.09	±0.92
13.3	+1.2/+0.4	13.0	1.0 ±0.15	4.4 0/-0.6	≤0.18	68.87	70.74	72.68	±1.00
14.3	+1.4/+0.4	14.0	0.8 ±0.15	3.5 0/-0.4	≤0.18	74.17	76.18	78.27	±1.08
14.3	+1.4/+0.4	14.0	1.0 ±0.15	4.3 0/-0.6	≤0.18	74.17	76.18	78.27	±1.08
14.3	+1.4/+0.4	14.0	1.0 ±0.15	4.7 0/-0.6	≤0.18	74.17	76.18	78.27	±1.08
14.3	+1.4/+0.4	14.0	1.4 ±0.15	4.5 0/-0.6	≤0.18	74.17	76.18	78.27	±1.08
16.3	+1.4/+0.4	16.0	2.0 ±0.20	8.0 0/-0.6	≤0.20	84.77	87.06	89.45	±1.23
16.3	+1.4/+0.4	16.0	2.2 ±0.20	8.2 0/-0.8	≤0.20	84.77	87.06	89.45	±1.23
16.3	+1.4/+0.4	16.0	1.2 ±0.15	5.5 0/-0.8	≤0.20	84.77	87.06	89.45	±1.23
18.3	+1.4/+0.4	18.0	1.75 ±0.20	9.15 0/-0.8	≤0.20	95.36	97.95	100.63	±1.38
18.3	+1.4/+0.4	18.0	1.4 ±0.15	6.3 0/-0.8	≤0.20	95.36	97.95	100.63	±1.38
20.3	+1.4/+0.4	20.0	1.5 ±0.15	7.1 0/-0.8	≤0.20	105.96	108.83	111.81	±1.54
20.3	+1.4/+0.4	20.0	2.0 ±0.25	9.9 0/-1.0	≤0.20	105.96	108.83	111.81	±1.54
20.3	+1.4/+0.4	20.0	2.5 ±0.30	9.8 0/-1.0	≤0.20	105.96	108.83	111.81	±1.54
21.3	+1.4/+0.4	21.0	1.4 ±0.15	7.1 0/-0.8	≤0.20	111.26	114.27	117.4	±1.60
22.3	+1.4/+0.4	22.0	2.0 ±0.25	10.7 0/-1.0	≤0.20	116.56	119.71	123.00	±1.69
25.3	+1.4/+0.4	25.0	3.0 ±0.30	11.75 0/-1.0	≤0.20	132.45	136.03	139.77	±1.92
26.3	+1.4/+0.4	26.0	2.0 ±0.25	11.0 0/-1.0	≤0.20	137.75	141.48	145.36	±2.00

*CO=centre offset
MORE TYPES ARE AVAILABLE ON REQUEST!

2 coolant holes, 40° helix

Length:330/310mm and fix lengths

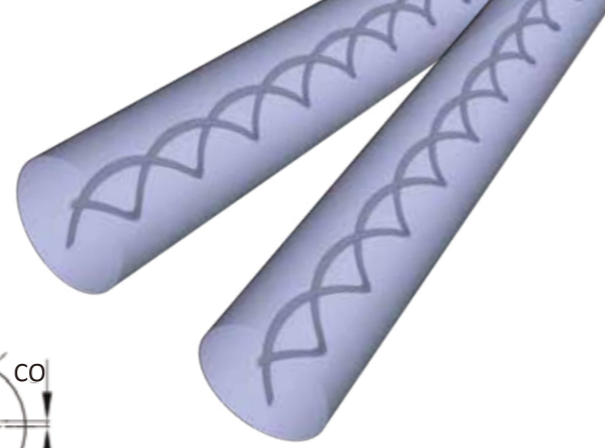
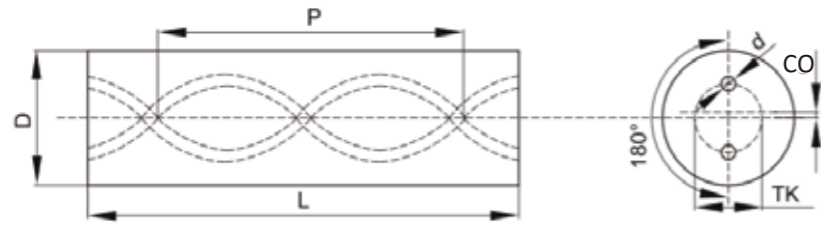

D mm	D h5/h6 mm	d mm	TK mm	CO* mm	Pitch				
					P1	P2	P3	Tol.	
6.3	+1.0/+0.4	6.0	0.3 ±0.10	1.0 ±0.15	≤0.10	21.68	22.46	23.28	±0.42
6.3	+1.0/+0.4	6.0	0.5 ±0.15	2.2 0/-0.4	≤0.10	21.68	22.46	23.28	±0.42
6.3	+1.0/+0.4	6.0	0.7 +0.1/-0.15	1.3 ±0.15	≤0.15	21.68	22.46	23.28	±0.42
6.3	+1.0/+0.4	6.0	0.4 ±0.10	1.5 ±0.20	≤0.10	21.68	22.46	23.28	±0.42
6.3	+1.0/+0.4	6.0	0.7 +0.1/-0.15	1.9 0/-0.4	≤0.15	21.68	22.46	23.28	±0.42
8.3	+1.0/+0.4	8.0	0.4 ±0.10	1.7 0/-0.4	≤0.10	28.91	29.95	31.04	±0.56
8.3	+1.0/+0.4	8.0	0.65 ±0.15	2.7 0/-0.6	≤0.10	28.91	29.95	31.04	±0.56
10.3	+1.0/+0.4	10.0	0.8 ±0.15	3.5 0/-0.8	≤0.15	36.14	37.44	38.8	±0.70
12.3	+1.0/+0.4	12.0	0.9 ±0.15	4.2 0/-0.8	≤0.18	43.37	44.93	46.55	±0.84
14.3	+1.4/+0.4	14.0	0.7 ±0.15	2.9 0/-0.4	≤0.18	50.6	52.42	54.31	±0.98
14.3	+1.4/+0.4	14.0	1.0 ±0.20	4.7 0/-0.8	≤0.18	50.6	52.42	54.31	±0.98
16.3	+1.4/+0.4	16.0	1.2 ±0.20	5.5 0/-0.8	≤0.20	57.82	59.9	62.07	±1.12
18.3	+1.4/+0.4	18.0	1.3 ±0.20	4.2 0/-0.8	≤0.20	65.05	67.39	69.83	±1.26
18.3	+1.4/+0.4	18.0	1.4 ±0.20	6.3 0/-0.8	≤0.20	65.05	67.39	69.83	±1.26
20.3	+1.4/+0.4	20.0	1.5 ±0.20	7.1 0/-1.0	≤0.20	72.28	74.88	77.59	±1.40

*CO=centre offset
MORE TYPES ARE AVAILABLE ON REQUEST!

2 coolant holes, 45° helix

Length:330/310mm and fix lengths

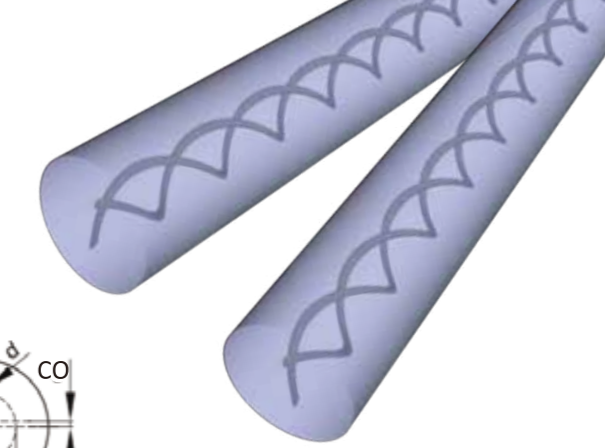
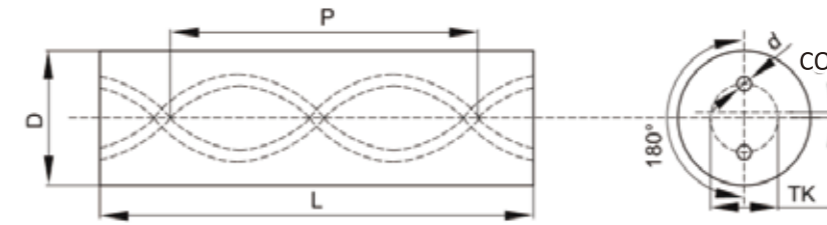

D mm	D h5/h6 mm	d mm	TK mm	CO* mm	Pitch				
					P1	P2	P3	Tol.	
6.3	+1.0/+0.4	6.0	0.6 ±0.15	1.9 0/-0.4	≤0.10	18.2	18.85	19.52	±0.34

*CO=centre offset
MORE TYPES ARE AVAILABLE ON REQUEST!

3 coolant holes, 30° helix

Length:330/310mm and fix lengths

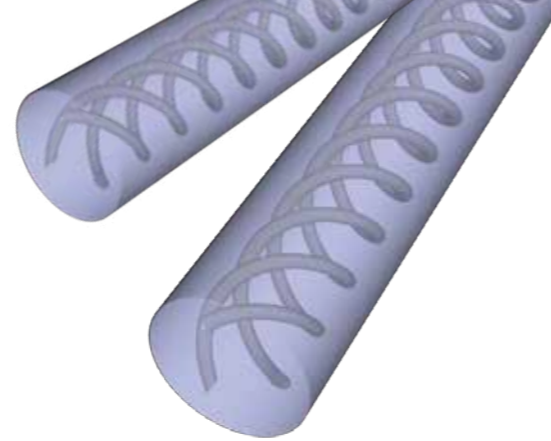
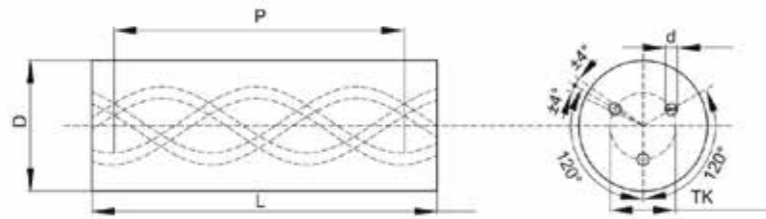

D mm	D h5/h6 mm	d mm	TK mm	CO* mm	Pitch					
					P1	P2	P3	Tol.		
6.3	+1.0/+0.4	6.0	0.5 ±0.15	2.9	0/-0.4	±4°	31.79	32.65	33.54	±0.46
8.3	+1.0/+0.4	8.0	0.7 ±0.15	4	0/-0.4	±4°	42.38	43.53	44.73	±0.62
9.3	+1.0/+0.4	9.0	0.85 ±0.15	5.1	0/-0.5	±4°	47.68	48.97	50.32	±0.69
10.3	+1.1/+0.4	10.0	0.85 ±0.15	5.1	0/-0.4	±4°	52.98	54.41	55.91	±0.77
10.3	+1.1/+0.4	10.0	0.8 ±0.15	3.5	0/-0.4	±4°	52.98	54.41	55.91	±0.77
12.3	+1.1/+0.4	12.0	1.1 ±0.15	6.3	0/-0.6	±4°	63.58	65.3	67.09	±0.92
14.3	+1.4/+0.4	14.0	1.4 ±0.20	7.3	0/-0.8	±4°	74.17	76.18	78.27	±1.08
15.3	+1.4/+0.4	15.0	1.4 ±0.20	7.8	0/-0.8	±4°	79.47	81.62	83.86	±1.15
16.3	+1.4/+0.4	16.0	1.6 ±0.20	8.3	0/-0.8	±4°	84.77	87.06	89.45	±1.23
18.3	+1.4/+0.4	18.0	1.7 ±0.20	9.5	0/-0.8	±4°	95.36	97.95	100.63	±1.38
20.3	+1.4/+0.4	20.0	1.9 ±0.25	10.2	0/-0.8	±4°	105.96	108.83	111.81	±1.54
22.3	+1.4/+0.4	22.0	2.0 ±0.25	10.7	0/-1.0	±4°	116.56	119.71	123.00	±1.69
22.3	+1.4/+0.4	22.0	2.0 ±0.25	11.5	0/-0.8	±4°	116.56	119.71	123.00	±1.69
24.3	+1.4/+0.4	24.0	2.0 ±0.25	12.5	0/-0.8	±4°	127.15	130.59	134.18	±1.85
24.3	+1.4/+0.4	24.0	2.0 ±0.25	12.1	0/-0.8	±4°	127.15	130.59	134.18	±1.85
25.3	+1.4/+0.4	25.0	2.0 ±0.25	12.5	0/-0.8	±4°	132.45	136.03	139.77	±1.92

*CO=centre offset
MORE TYPES ARE AVAILABLE ON REQUEST!

3 coolant holes, 40° helix

Length:330/310mm and fix lengths

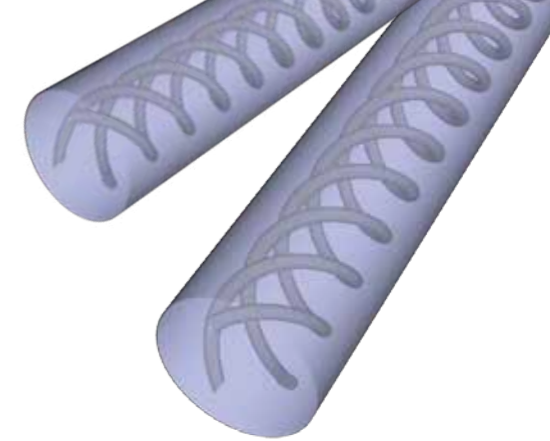
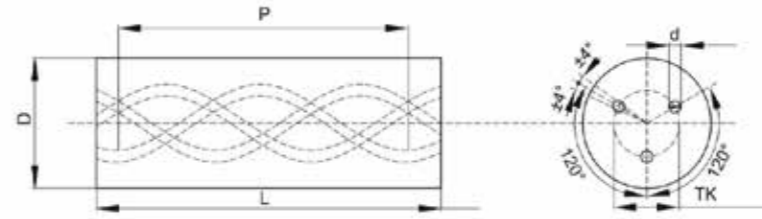

D mm	D h5/h6 mm	d mm	TK mm	CO* mm	Pitch					
					P1	P2	P3	Tol.		
6.3	+1.0/+0.4	6.0	0.5 ±0.15	2.2	0/-0.4	±4°	21.68	22.46	23.28	±0.42
8.3	+1.0/+0.4	8.0	0.65 ±0.15	2.7	0/-0.4	±4°	28.91	29.95	31.04	±0.56
10.3	+1.1/+0.4	10.0	0.8 ±0.15	3.5	0/-0.4	±4°	36.14	37.44	38.8	±0.70
12.3	+1.1/+0.4	12.0	0.9 ±0.15	4.2	0/-0.6	±4°	43.37	44.93	46.55	±0.84
14.3	+1.4/+0.4	14.0	1.0 ±0.20	4.7	0/-0.6	±4°	50.6	52.42	54.31	±0.98
16.3	+1.4/+0.4	16.0	1.2 ±0.20	5.5	0/-0.8	±4°	57.82	59.9	62.07	±1.12
18.3	+1.4/+0.4	18.0	1.4 ±0.20	6.3	0/-0.8	±4°	65.05	67.39	69.83	±1.26
20.3	+1.4/+0.4	20.0	1.5 ±0.25	7.1	0/-0.8	±4°	72.28	74.88	77.59	±1.4

*CO=centre offset
MORE TYPES ARE AVAILABLE ON REQUEST!

Central coolant hole

Length:330/310mm and fix lengths

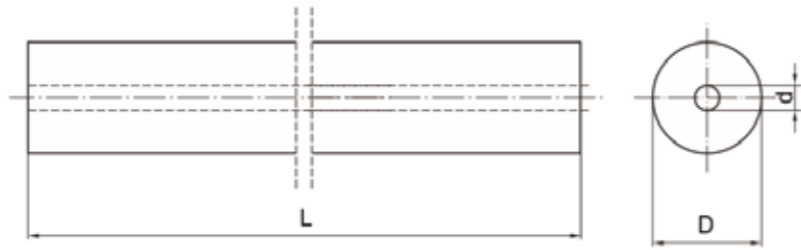

D mm	D h5/h6 mm	d mm	CO* mm	
4.0	+0.2/+0.6	4.0	1.0 ±0.15	≤0.2
5.0	+0.2/+0.6	5.0	1.0 ±0.15	≤0.2
5.0	+0.2/+0.6	5.0	1.5 ±0.15	≤0.2
6.0	+0.2/+0.6	6.0	1.0 ±0.15	≤0.2
6.0	+0.2/+0.6	6.0	1.5 ±0.15	≤0.2
7.0	+0.2/+0.6	7.0	1.0 ±0.15	≤0.2
8.0	+0.2/+0.6	8.0	1.0 ±0.15	≤0.25
8.0	+0.3/+0.7	8.0	1.5 ±0.15	≤0.25
9.0	+0.3/+0.7	9.0	1.0 ±0.15	≤0.25
10.0	+0.3/+0.7	10.0	1.0 ±0.15	≤0.25
10.0	+0.3/+0.7	10.0	2.0 ±0.2	≤0.25
11.0	+0.3/+0.7	11.0	1.0 ±0.15	≤0.25
12.0	+0.3/+0.7	12.0	1.0 ±0.15	≤0.25
12.0	+0.3/+0.7	12.0	2.0 ±0.2	≤0.25
14.0	+0.3/+0.7	14.0	2.0 ±0.2	≤0.25
16.0	+0.4/+0.8	16.0	2.0 ±0.2	≤0.25
16.0	+0.4/+0.8	16.0	3.0 ±0.25	≤0.25
18.0	+0.4/+0.8	18.0	3.0 ±0.25	≤0.3
20.0	+0.4/+0.8	20.0	3.0 ±0.25	≤0.3

*CO=centre offset
MORE TYPES ARE AVAILABLE ON REQUEST!

2 Parallel holes

Length:330/310mm and fix lengths

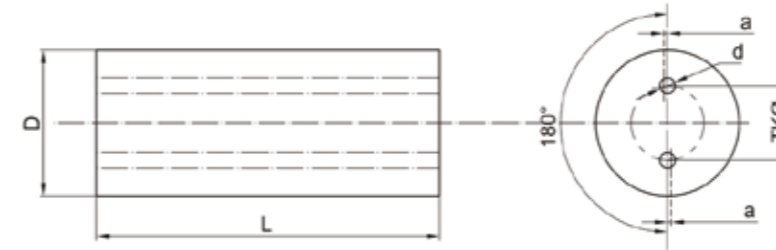

D mm	d h5/h6 mm	d mm	TK mm	CO* mm	
4.3	0/+0.6	4.0	0.8 ±0.10	1.8 0/-0.4	≤0.15
5.3	0/+0.6	5.0	0.8 ±0.10	2.0 0/-0.4	≤0.20
6.3	0/+0.6	6.0	1.0 ±0.15	3.0 0/-0.5	≤0.20
7.3	0/+0.6	7.0	1.0 ±0.15	3.5 0/-0.5	≤0.20
8.3	0/+0.6	8.0	1.0 ±0.15	4.0 0/-0.6	≤0.20
9.3	0/+0.6	9.0	1.4 ±0.15	4.0 0/-0.6	≤0.20
10.3	0/+0.6	10.0	1.4 ±0.15	5.0 0/-0.6	≤0.20
11.3	0/+0.6	11.0	1.4 ±0.15	5.0 0/-0.6	≤0.28
12.3	0/+0.6	12.0	1.75 ±0.15	6.0 0/-0.6	≤0.30
13.3	0/+0.6	13.0	1.75 ±0.15	6.0 0/-0.6	≤0.34
14.3	0/+0.6	14.0	1.75 ±0.15	7.0 0/-0.6	≤0.37
15.3	0/+0.6	15.0	2.0 ±0.20	7.0 0/-0.6	≤0.37
16.3	0/+0.6	16.0	2.0 ±0.20	8.0 0/-0.6	≤0.40
17.3	0/+0.8	17.0	2.0 ±0.20	8.0 0/-0.6	≤0.47
18.3	0/+0.8	18.0	2.0 ±0.20	9.0 0/-0.6	≤0.50
19.3	0/+0.8	19.0	2.0 ±0.20	9.0 0/-0.6	≤0.50
20.3	0/+0.8	20.0	2.5 ±0.25	10.0 0/-0.8	≤0.50

*CO=centre offset
MORE TYPES ARE AVAILABLE ON REQUEST!

Length Tolerance of coolant rods

D mm Range	L mm Range	L Tol. mm
<18.3	>100	0/+0.7
	<100	0/+0.5
≥18.3		+3.0/+10.0



Carbide rods for PCB tools

For Router



D mm	L* mm	YU06A	XN208	XF15S	XN20A
3.21	0/+0.02	38.5	-0.10/+0.20	★	★
3.21	0/+0.02	38.7	-0.20/+0.30	★	★

D mm	L mm	XN209	YU06A		
0.8	0/+0.1	330	0/+5	★	★
1.15	0/+0.1	330	0/+5	★	★
1.35	0/+0.1	330	0/+5	★	★
1.5	0/+0.1	330	0/+5	★	★
1.8	0/+0.1	330	0/+5	★	★
2.0	0/+0.1	330	0/+5	★	★
2.25	0/+0.1	330	0/+10	★	★
2.5	0/+0.1	330	0/+5	★	★

★ Recommended Grade
*Available as any fix length

MORE TYPES ARE AVAILABLE ON REQUEST!

Carbide rods for PCB tools

For Step Drill



D mm	L mm	YU06A	XN208		
3.5	+0.05/+0.25	38.5	±0.20	★	★
4.0	+0.05/+0.25	38.5	±0.20	★	★
4.5	+0.05/+0.25	38.5	±0.20	★	★
5.0	+0.05/+0.25	38.5	±0.20	★	★
5.5	+0.05/+0.25	38.5	±0.20	★	★
6.0	+0.05/+0.25	38.5	±0.20	★	★
6.5	+0.05/+0.25	38.5	±0.20	★	★

★ Recommended Grade

MORE TYPES ARE AVAILABLE ON REQUEST!

Carbide rods for PCB tools

For Brazed Rods



D mm		L* mm		YU06A
3.5	-0.05/+0.05	12.2	0~0.4	★
3.75	-0.05/+0.05	12.2	0~0.4	★
4.0	-0.05/+0.05	12.2	0~0.4	★
4.25	-0.05/+0.05	12.2	0~0.4	★
4.5	-0.05/+0.05	12.2	0~0.4	★
4.75	-0.05/+0.05	12.2	0~0.4	★
5.0	-0.05/+0.05	12.2	0~0.4	★
5.25	-0.05/+0.05	12.2	0~0.4	★
5.5	-0.05/+0.05	12.2	0~0.4	★
5.75	-0.05/+0.05	12.2	0~0.4	★
6.0	-0.05/+0.05	12.2	0~0.4	★

★ Recommended Grade
* Available as any fix length

MORE TYPES ARE AVAILABLE ON REQUEST!



GUN DRILLS



Gun Drill blank

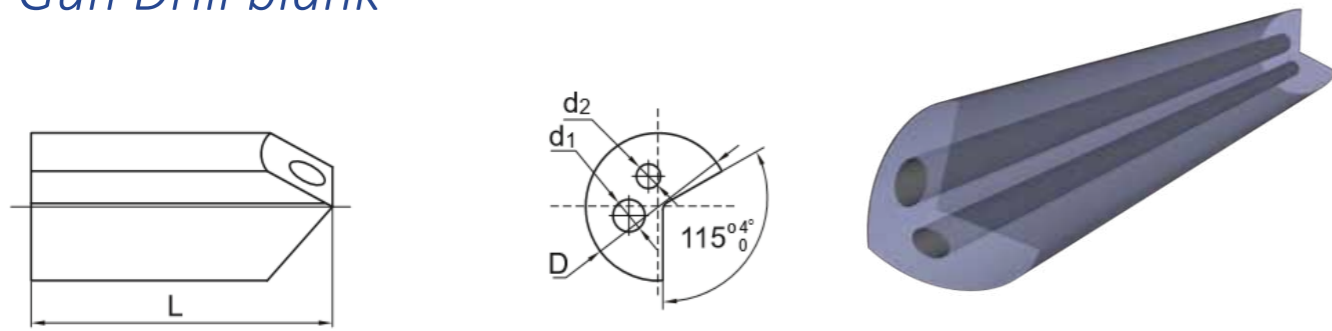

D mm	d1 mm	d2 mm	L mm
8.0	+0.2/+0.5	1.75 ±0.15	35 0/+3.0
8.5	0/+0.4	1.9 ±0.15	35 0/+3.0
9.0	+0.2/+0.5	2.1 ±0.15	35 0/+3.0
9.5	0/+0.4	2.1 ±0.15	35 0/+3.0
10.0	+0.2/+0.5	2.5 ±0.2	40 0/+3.0
10.5	0/+0.4	2.5 ±0.2	40 0/+3.0
11.0	+0.2/+0.5	2.7 ±0.2	40 0/+3.0
11.5	0/+0.4	2.7 ±0.2	40 0/+3.0
12.0	+0.2/+0.5	2.9 ±0.2	40 0/+3.0
12.5	0/+0.5	2.9 ±0.2	40 0/+3.0
13.0	+0.2/+0.5	3.2 ±0.2	40 0/+3.0
13.5	0/+0.5	3.2 ±0.2	40 0/+3.0
14.0	+0.2/+0.5	3.5 ±0.25	40 0/+3.0
14.5	0/+0.5	3.5 ±0.25	40 0/+3.0
15.0	+0.2/+0.5	3.8 ±0.25	40 0/+3.0
15.5	0/+0.5	3.8 ±0.25	40 0/+3.0
16.0	+0.2/+0.5	4.0 ±0.25	42 0/+3.0
16.5	0/+0.5	4.0 ±0.25	42 0/+3.0
17.0	+0.2/+0.5	4.2 ±0.25	42 0/+3.0
17.5	0/+0.5	4.2 ±0.25	42 0/+3.0
18.0	+0.2/+0.5	4.5 ±0.25	48 0/+3.0
18.5	+0.1/+0.6	4.5 ±0.25	48 0/+3.0
19.0	+0.2/+0.5	4.8 ±0.25	48 0/+3.0
19.5	+0.1/+0.6	4.8 ±0.25	48 0/+3.0
20.0	+0.2/+0.5	5.0 ±0.25	50 0/+3.0
20.5	+0.1/+0.6	5.0 ±0.3	50 0/+3.0
21.0	+0.2/+0.5	5.3 ±0.25	50 0/+3.0
21.5	+0.1/+0.6	5.3 ±0.3	50 0/+3.0
22.0	+0.2/+0.5	5.1 ±0.3	55 0/+3.0

MORE TYPES ARE AVAILABLE ON REQUEST!

Gun Drill blank

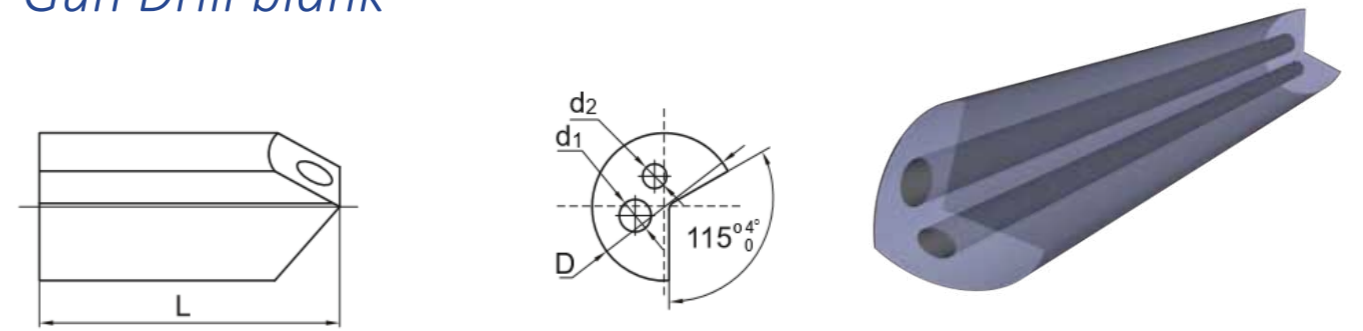

D mm	d1 mm	d2 mm	L mm
22.5	+0.1/+0.6	5.1 ±0.3	55 0/+3.0
23.0	+0.2/+0.6	5.8 ±0.3	55 0/+3.0
23.5	+0.1/+0.6	5.3 ±0.3	55 0/+3.0
24.0	+0.2/+0.6	6.0 ±0.3	55 0/+3.0
24.5	+0.1/+0.6	5.5 ±0.3	55 0/+3.0
25.0	+0.2/+0.6	6.3 ±0.3	60 0/+3.0
25.5	+0.1/+0.6	5.8 ±0.35	60 0/+3.0
26.0	+0.2/+0.6	6.6 ±0.3	60 0/+3.0
26.5	+0.1/+0.7	6.1 ±0.35	60 0/+3.0
27.0	+0.2/+0.6	6.5 ±0.35	60 0/+3.0
27.5	+0.1/+0.7	5.3 ±0.35	60 0/+3.0
28.0	+0.2/+0.6	7.0 ±0.35	65 0/+3.0
28.5	+0.1/+0.7	7.0 ±0.35	65 0/+3.0
29.0	+0.2/+0.6	7.2 ±0.35	65 0/+3.0
29.5	+0.1/+0.7	6.2 ±0.35	65 0/+3.0
30.0	+0.2/+0.6	7.4 ±0.35	65 0/+3.0
30.5	+0.1/+0.8	7.4 ±0.35	65 0/+3.0
31.0	+0.2/+0.6	7.0 ±0.35	65 0/+3.0
31.5	+0.1/+0.8	7.0 ±0.35	65 0/+3.0
32.0	+0.2/+0.6	7.5 ±0.35	65 0/+3.0
32.5	+0.2/+0.9	7.6 ±0.35	65 0/+3.0
33.0	+0.2/+0.6	7.6 ±0.35	65 0/+3.0
33.5	+0.2/+0.9	6.5 ±0.35	65 0/+3.0
34.0	+0.2/+0.6	6.5 ±0.35	65 0/+3.0
34.5	+0.2/+0.9	7.0 ±0.35	65 0/+3.0
35.0	+0.2/+0.6	7.0 ±0.35	65 0/+3.0
35.5	+0.2/+0.9	7.5 ±0.35	65 0/+3.0
36.0	+0.2/+0.6	7.5 ±0.35	65 0/+3.0
36.5	+0.2/+0.9	7.6 ±0.35	65 0/+3.0

MORE TYPES ARE AVAILABLE ON REQUEST!

Gun Drill blank

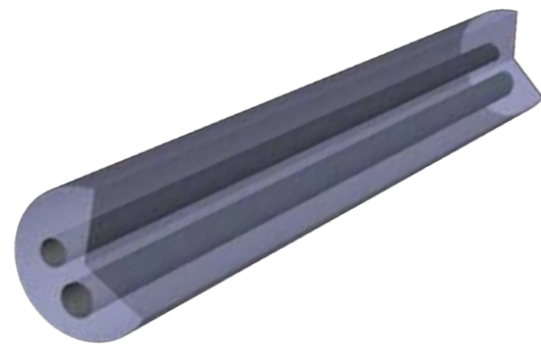

D mm		d1 mm		d2 mm	
8.0	+0.2/+0.5	1.75	±0.15	1.45	±0.15
8.5	0/+0.4	1.9	±0.15	1.5	±0.15
9.0	+0.2/+0.5	2.1	±0.15	1.65	±0.15
9.5	0/+0.4	2.1	±0.15	1.65	±0.15
10.0	+0.2/+0.5	2.5	±0.2	1.95	±0.2
10.5	0/+0.4	2.5	±0.2	1.95	±0.2
11.0	+0.2/+0.5	2.7	±0.2	2.1	±0.2
11.5	0/+0.4	2.7	±0.2	2.1	±0.2
12.0	+0.2/+0.5	2.9	±0.2	2.3	±0.2
12.5	0/+0.5	2.9	±0.2	2.3	±0.2
13.0	+0.2/+0.5	3.2	±0.2	2.6	±0.2
13.5	0/+0.5	3.2	±0.2	2.6	±0.2
14.0	+0.2/+0.5	3.5	±0.25	2.8	±0.25
14.5	0/+0.5	3.5	±0.25	2.8	±0.25
15.0	+0.2/+0.5	3.8	±0.25	3.0	±0.25
15.5	0/+0.5	3.8	±0.25	3.0	±0.25
16.0	+0.2/+0.5	4.0	±0.25	3.2	±0.25
16.5	0/+0.5	4.0	±0.25	3.2	±0.25
17.0	+0.2/+0.5	4.2	±0.25	3.4	±0.25
17.5	0/+0.5	4.2	±0.25	3.4	±0.25
18.0	+0.2/+0.5	4.5	±0.25	3.6	±0.25
18.5	+0.1/+0.6	4.5	±0.25	3.6	±0.25
19.0	+0.2/+0.5	4.8	±0.25	3.8	±0.25
19.5	+0.1/+0.6	4.8	±0.25	3.8	±0.25
20.0	+0.2/+0.5	5.0	±0.25	4.0	±0.25
20.5	+0.1/+0.6	5.0	±0.3	4.0	±0.3
21.0	+0.2/+0.5	5.3	±0.25	4.2	±0.25
21.5	+0.1/+0.6	5.3	±0.3	4.2	±0.3
22.0	+0.2/+0.5	5.1	±0.3	4.0	±0.3

MORE TYPES ARE AVAILABLE ON REQUEST!

Gun Drill blank

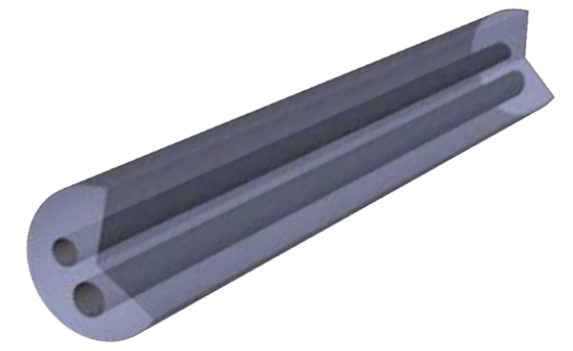
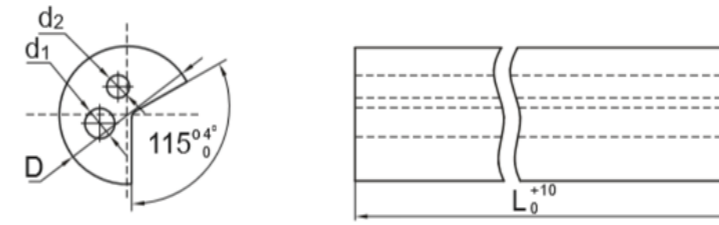

D mm		d1 mm		d2 mm	
22.5	+0.1/+0.6	5.1	±0.3	4.0	±0.3
23.0	+0.2/+0.6	5.8	±0.3	4.5	±0.3
23.5	+0.1/+0.6	5.3	±0.3	4.2	±0.3
24.0	+0.2/+0.6	6.0	±0.3	4.8	±0.3
24.5	+0.1/+0.6	5.5	±0.3	4.4	±0.3
25.0	+0.2/+0.6	6.3	±0.3	5.0	±0.3
25.5	+0.1/+0.6	5.8	±0.35	4.6	±0.35
26.0	+0.2/+0.6	6.6	±0.3	5.3	±0.3
26.5	+0.1/+0.7	6.1	±0.35	4.8	±0.35
27.0	+0.2/+0.6	6.5	±0.35	5.0	±0.35
27.5	+0.1/+0.7	5.3	±0.35	4.5	±0.35
28.0	+0.2/+0.6	7.0	±0.35	5.6	±0.35
28.5	+0.1/+0.7	7.0	±0.35	5.6	±0.35
29.0	+0.2/+0.6	7.2	±0.35	5.8	±0.35
29.5	+0.1/+0.7	6.2	±0.35	5.2	±0.35
30.0	+0.2/+0.6	7.4	±0.35	6.0	±0.35
30.5	+0.1/+0.8	7.4	±0.35	6.0	±0.35
31.0	+0.2/+0.6	7.0	±0.35	6.0	±0.35
31.5	+0.1/+0.8	7.0	±0.35	6.0	±0.35
32.0	+0.2/+0.6	7.5	±0.35	6.3	±0.35
32.5	+0.2/+0.9	7.6	±0.35	6.5	±0.35
33.0	+0.2/+0.6	7.6	±0.35	6.5	±0.35
33.5	+0.2/+0.9	6.5	±0.35	5.5	±0.35
34.0	+0.2/+0.6	6.5	±0.35	5.5	±0.35
34.5	+0.2/+0.9	7.0	±0.35	6.0	±0.35
35.0	+0.2/+0.6	7.0	±0.35	6.0	±0.35
35.5	+0.2/+0.9	7.5	±0.35	6.5	±0.35
36.0	+0.2/+0.6	7.5	±0.35	6.5	±0.35
36.5	+0.2/+0.9	7.6	±0.35	6.5	±0.35

MORE TYPES ARE AVAILABLE ON REQUEST!

PREFORMS



Step rods

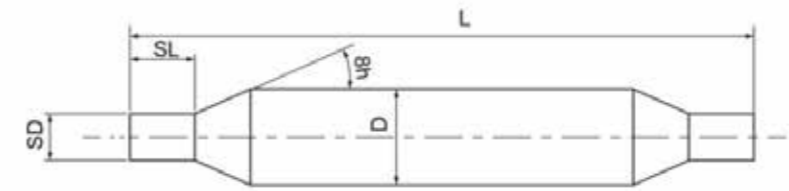

Cemented carbide blank for T-slot cutters

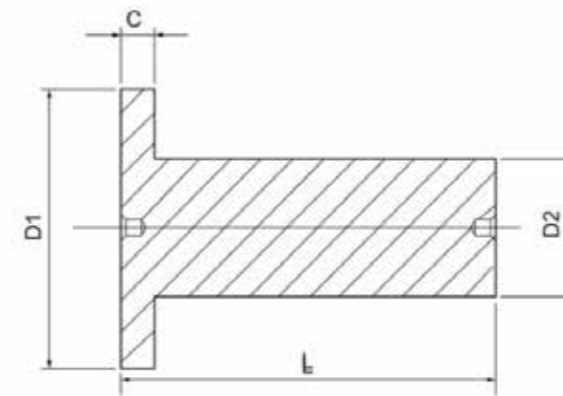

Rods with Kidney-Shaped coolant hole

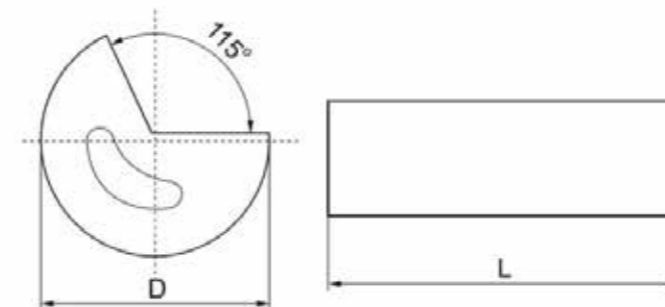

MORE TYPES ARE AVAILABLE ON REQUEST!

Rod with taper end (with hole)

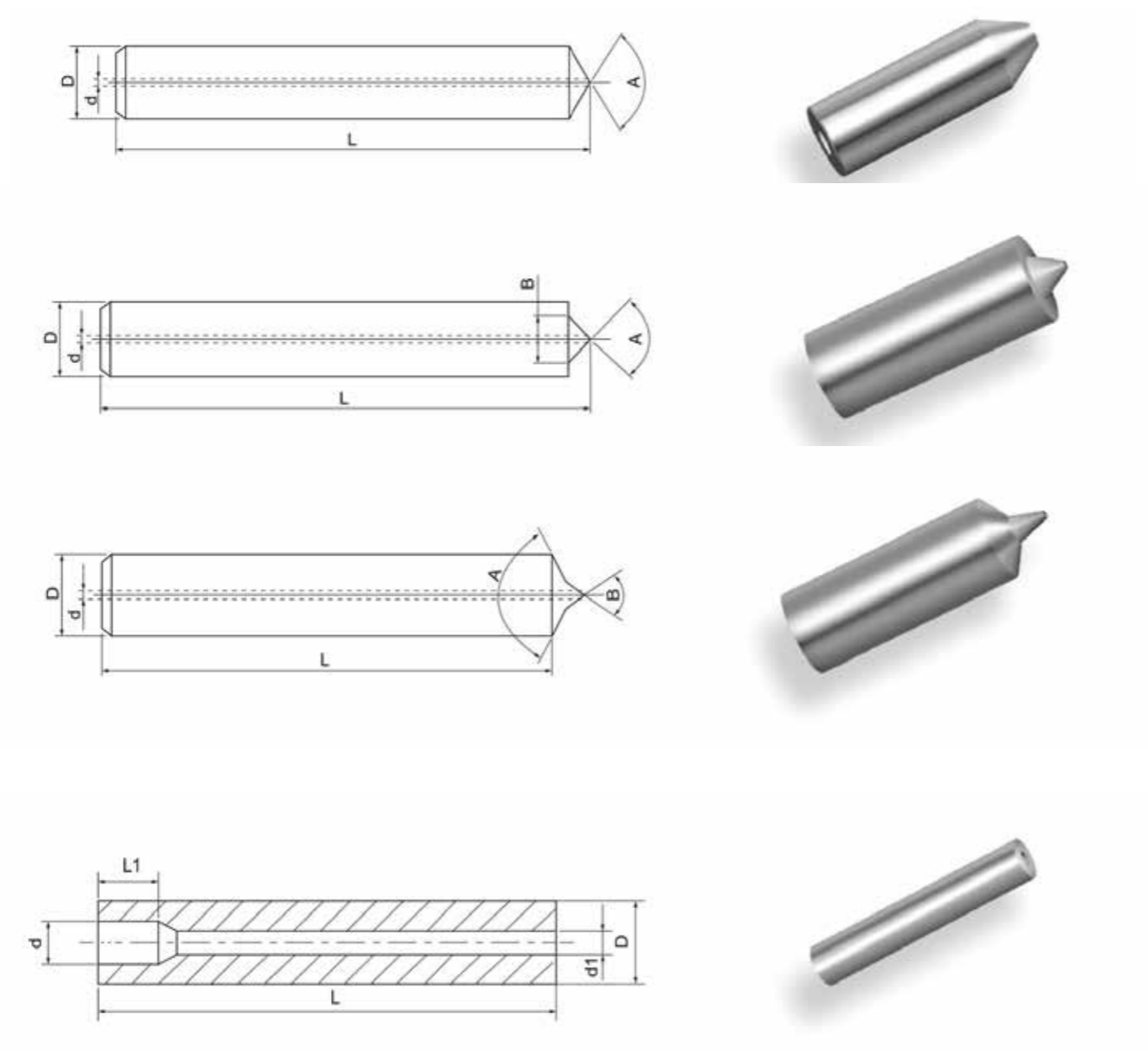

MORE TYPES ARE AVAILABLE ON REQUEST!

STRIPS

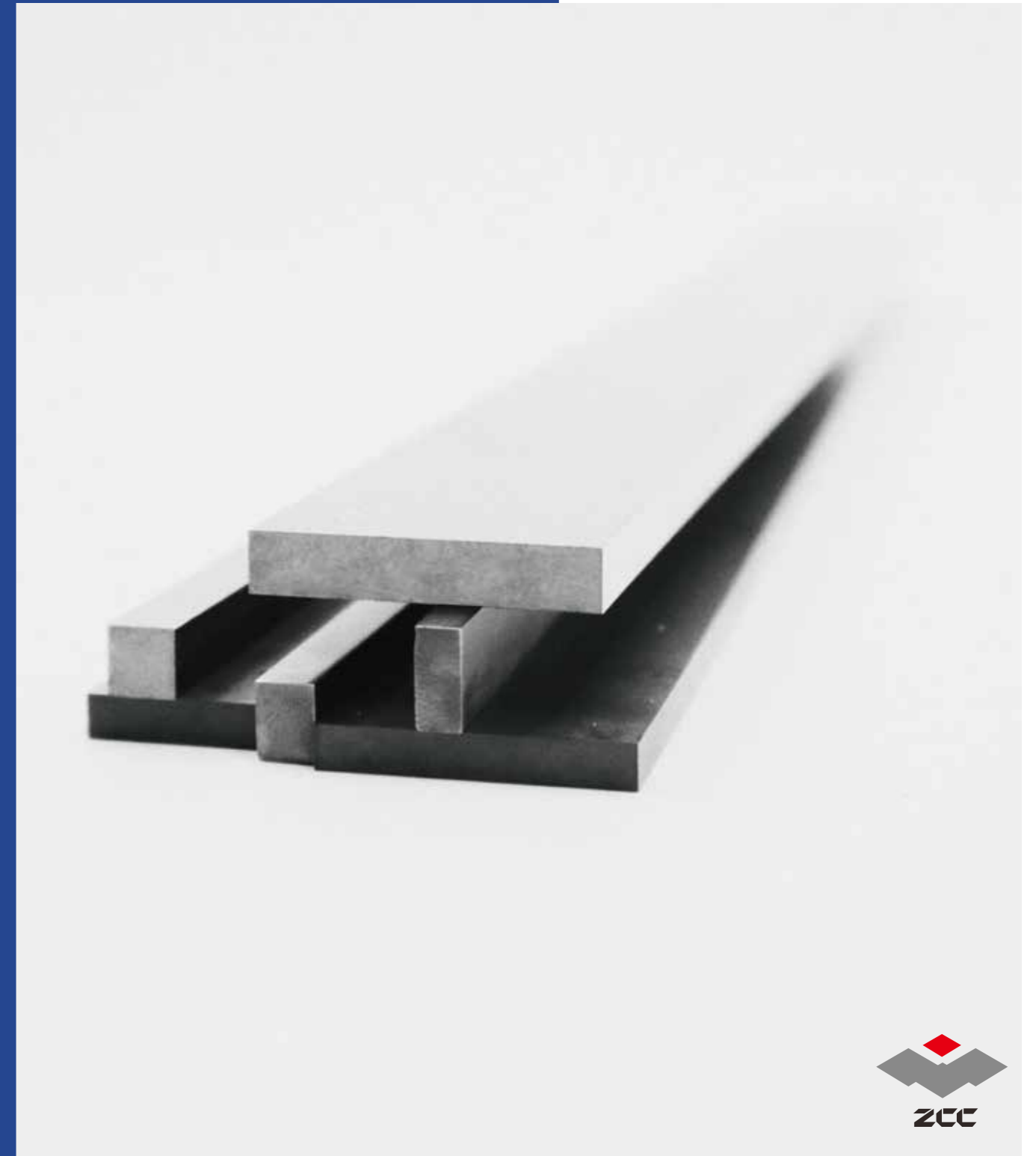

Strips

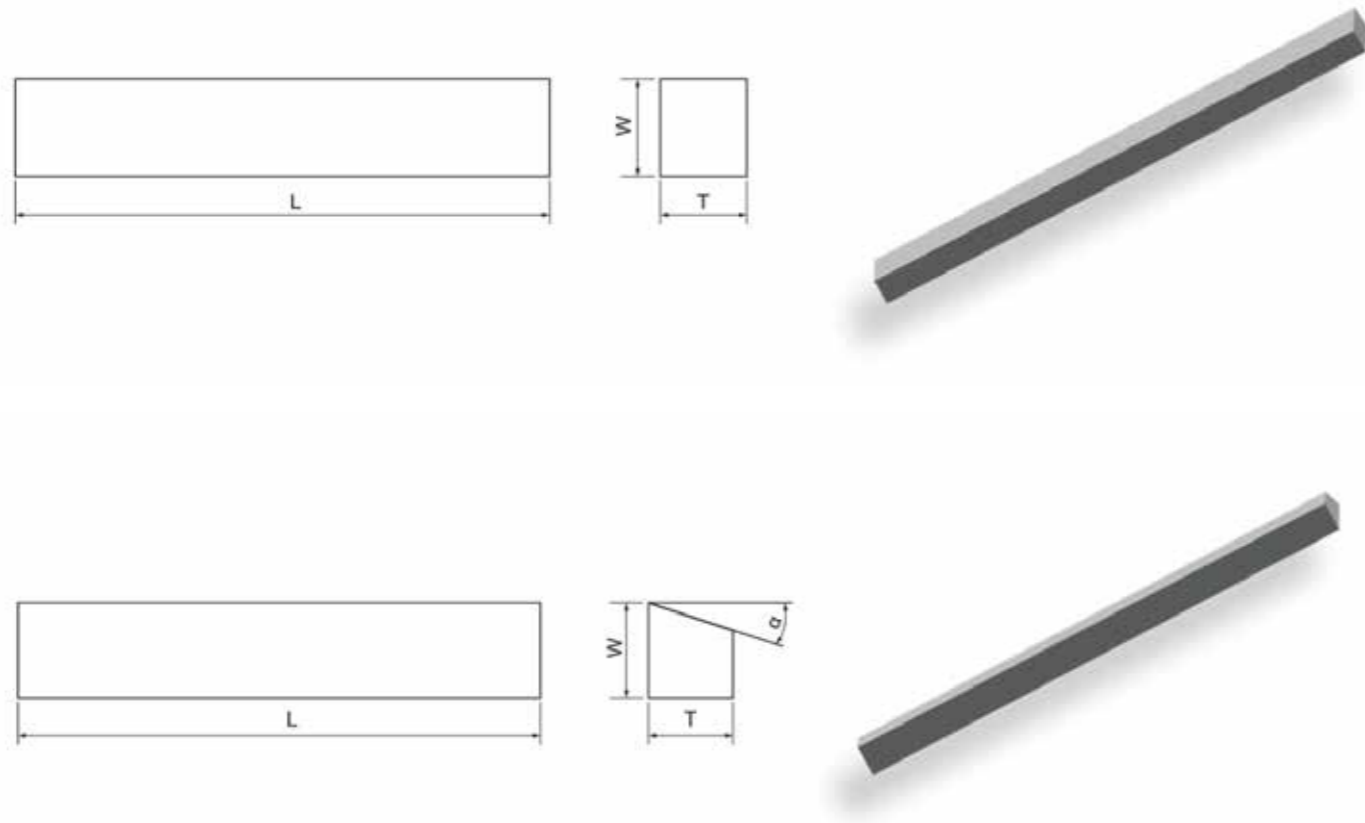

TYPE	Size range	Tol.
T(mm)	1.0 < T ≤ 16.0	+0.20/+0.80
W(mm)	1.0 ≤ W ≤ 32.0	+0.20/+1.0
L(mm)	260 ≤ L ≤ 700	0/+10.0
α(°)	0~35°	±1°

MORE TYPES ARE AVAILABLE ON REQUEST!

ISO Certificate





EXCELSIOR



PRECISION



FOCUS



DEDICATION



PASSION

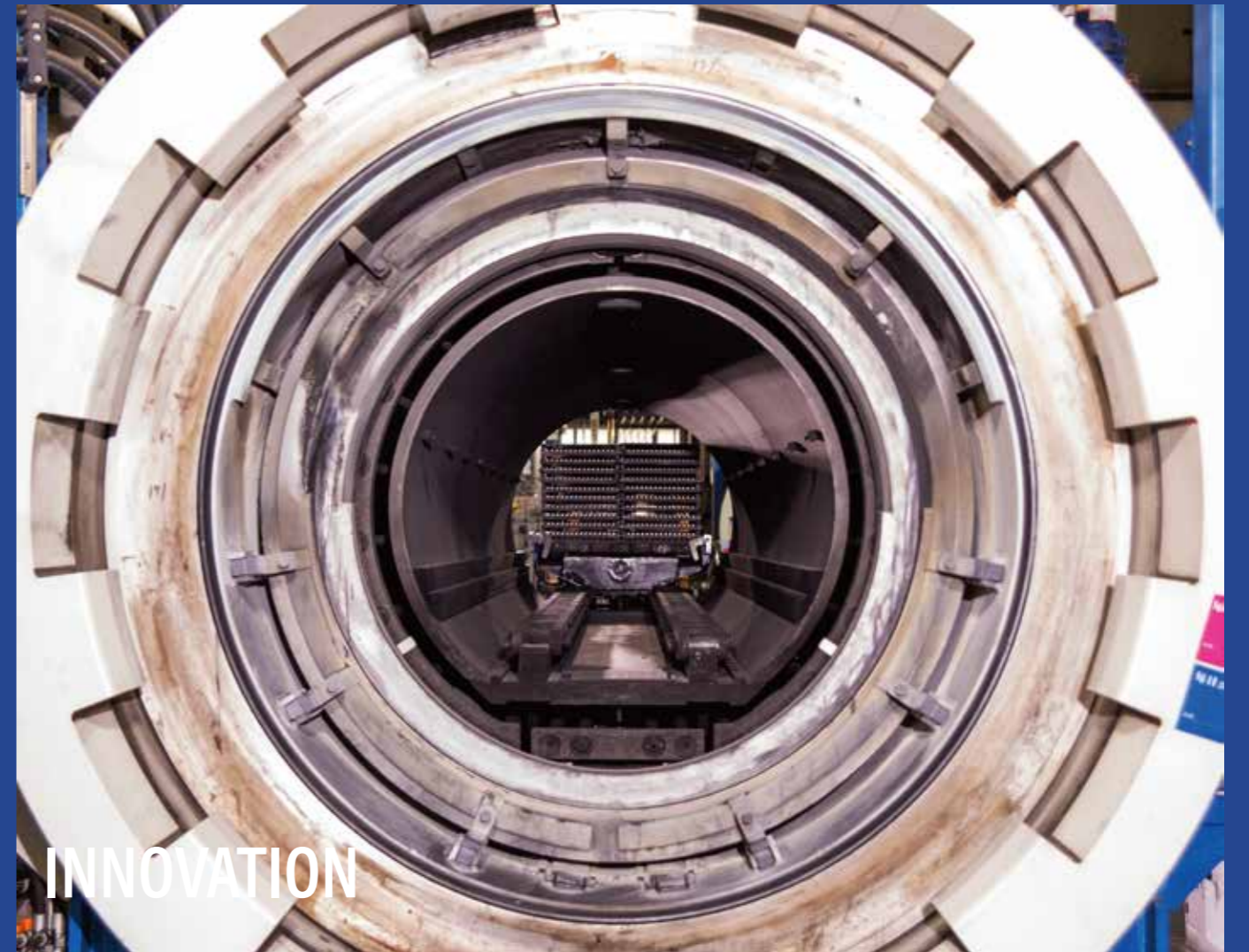

INNOVATION

